

# **'Aqualarm'**

## **ENVIRONMENTAL MONITORING SYSTEM**

***Installation, Set-up and Operating  
Instructions***

**'i-Zone'  
Systems**

## CONTENTS

<u>Section</u>		<u>Page No.</u>
<b>A</b>	<b>INSTALLATION</b>	
1.	<b>READ IMPORTANT INSTRUCTIONS</b>	4
2.	<i>Control Panel</i>	4
3.	<i>Interconnecting Cables</i>	4
4.	<i>Detector— Description</i>	5
5.	<i>Detector— Dipswitch Set-Up</i>	8
<b>B</b>	<b>CONTROL PANEL</b>	
1.	<i>Start-Up Procedure</i>	12
2.	<i>Set-Up Time &amp; Date</i>	15
<b>C</b>	<b>DETECTOR SET - UP</b>	
1.	<i>Important Information</i>	15
2.	<i>Detector Sensitivity</i>	17
3.	<i>Setting Alarm Thresholds.</i>	18
a.	<i>Liquid Detectors</i>	19
b.	<i>Refrigerant Gas Detectors</i>	19
c.	<i>Temperature Detectors</i>	20
d.	<i>Humidity Detectors</i>	20
4.	<i>ZLM-500 Mapping Procedure</i>	20
5.	<i>Hot Swapping</i>	22
<b>D</b>	<b>CONTROL PANEL FUNCTIONS</b>	
1.	<i>What to do if an Alarm Sounds</i>	23
a.	<i>Alarm (Detectors)</i>	23
b.	<i>Open Circuit (Detectors)</i>	24
2.	<i>ZLM-500 Locating Module</i>	25
a.	<i>Liquid Detected Alarm</i>	25
b.	<i>Open Circuit Alarm</i>	26
c.	<i>Network Fail</i>	26

**CONTENTS ..... (cont)**

<u>Section</u>		<u>Page No.</u>
<b>D</b>	<b>CONTROL PANEL FUNCTIONS</b>	
3.	<i>Mains Fail Alarm</i>	27
4.	<i>Battery Fail Alarm</i>	28
5.	<i>Mute &amp; Reset Keys</i>	28
6.	<i>View 255 Event Record Log</i>	29
<b>E</b>	<b>CONTROL PANEL OUTPUTS</b>	
1.	<i>Control Panel Relay Outputs</i>	30
2.	<i>Control Panel RS-485 Output</i>	30
<b>F</b>	<b>CARE &amp; MAINTENANCE</b>	
1.	<i>Care of Detecting Cables</i>	31
2.	<i>Maintenance</i>	31
<b>G</b>	<b>EQUIPMENT</b>	
1.	<i>Control Panel Terminals</i>	33
2.	<i>Ancillary Equipment</i>	33
3.	<i>PB-24 Power Booster Box</i>	34
4.	<i>SWRi-8 Relay Pack</i>	34
5.	<i>SWRi-5 Relay Pack</i>	37
6.	<i>Spares</i>	39
7.	<i>Control Panel Facia</i>	40
	<b>CERTIFICATES</b>	
	<i>ISO 9001</i>	41
	<i>ISO 14001</i>	42
	<i>WEE Regs. 2006</i>	43
	<i>Mapping Results Sheet</i>	44
	<b>CORRECT DISPOSAL OF PRODUCT</b>	
	<i>When finished with Use</i>	46

## **Section A**

### **Installation**

1. **READ THESE  
IMPORTANT INSTRUCTIONS  
BEFORE REMOVING THE SECURITY BAND**  
*To avoid damage to the electronics within the Control Panel  
It is strongly recommended that you use the knockouts  
provided for the entrance of Cables.*  
*If you have to drill holes for cables to enter the Control  
Panel, special care must be taken to ensure that drill bits do not  
penetrate far enough to touch the Printed Circuit Boards or any  
Component.*  
*You must ensure that any swarf from the drilling is  
completely removed from the Control Panel.*  
*FAILURE to adhere to the above may invalidate your  
Warranty.*
2. **Control Panel**
  - i. *The **i-Zone** Control Panel should be sited in a position where the  
'Alarm Horn' can be heard and at a height where the LCD Screen can  
be seen.*
  - ii. *A 220/240 volt 50 Hz single phase power supply via a 5 amp  
non-switched fused spur should be made available adjacent to the  
Control Panel prior to the start of the installation.*
  - iii. *The Mains Power terminals within the Control Panel are marked  
and should be connected as follows:-*  
*connect BROWN wire to TERMINAL marked 'L' (live)*  
*connect BLUE wire to TERMINAL marked 'N' (neutral)*  
*connect YELLOW/GREEN wire to TERMINAL marked 'E' (earth)*  
**(see drawing page 33)**  
**The Mains Power Supply should only be connected to the**

**Control Panel by a competent qualified person.**

**DO NOT CONNECT POWER TO THE CONTROL PANEL OR  
THE BATTERIES YET . (SEE PAGE 33 FOR CONNECTIONS.)**

**3. Interconnecting Cables.**

- i. Using a 120 ohm 0.5mm 4 core cable with twisted pairs and overall screen, (as **Belden Ref: B9842**), connect the detectors to the Control Panel as follows:- (**Network**)

## Section A ..... (cont.)

### 3. Interconnecting Cables..... (cont.)

- ii. From the Terminals marked **CAN** within the Control Panel, using **FIRST TWISTED PAIR**, connect **ONE** core to each of the terminals marked:- **V+**, **V-**. Using the **SECOND TWISTED PAIR** connect **ONE** core to each of the terminals marked:- **Hi**, **Lo**.
- iii. Connect in Series to the corresponding terminals within each of the Detectors in turn. Ensure that the cables are not cross connected. (see the following diagram)

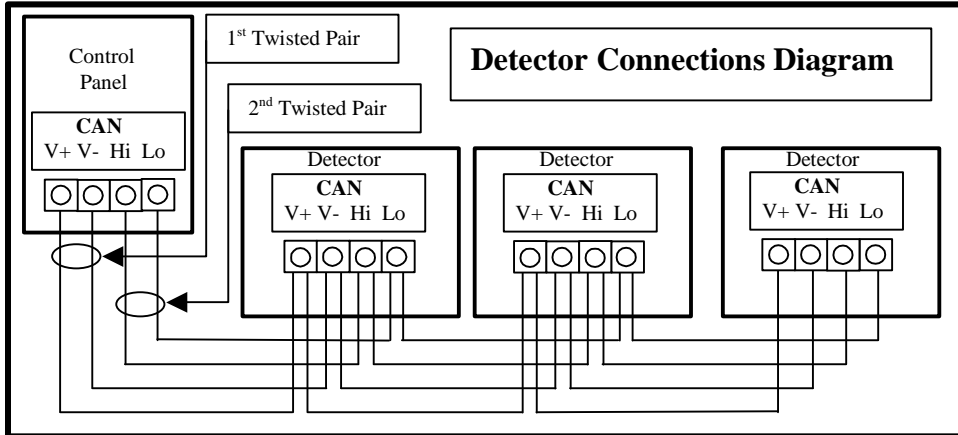

### 4. Detectors.

#### a. Thresholds.

- i. With the **exception** of the **Detector Address**, all detector thresholds are set with the factory default.
- ii. The parameters of Refrigerant Gas (RGi-24), Temperature (TDi-24) & Humidity (HDI-24) Detectors can be set with Clients thresholds via the Control Panel. (See page 18 on how to change thresholds)

#### b. Description

##### i. Point of Use Water Detector. (STDi-24)

Consists of 2 parts, a point Detector connected by a fly lead to a CDBi Module. The CDBi module can be mounted remotely with the Point of Use Detector normally sited at low points on the floor slab or adjacent to a potential leak e.g. A.C. unit, humidifier, water cooled equipment or water services pipe-work.

##### ii. Cable type Water Leak Detector (CDBi-24)

Consists of 2 parts, a CDBi Module plus modular lengths of Detecting Cable (CD-x). The CDBi module should be mounted at the start with the Detecting cable encircling the area, unit or pipe-work to be monitored.

#### b. Description ..... (cont.)

- iii. **Detecting cable (CD-x) (x = Length — 1, 2, 5 or 10 metres)** with a maximum length of 50 metres per Zone.
- iv. Detecting cable (CD-x) should be installed using the following methods:-
  - a. Clip to the underside of pipe-work using nylon type cable ties at 300 mm centres.
  - b. Clip to the floor slab or other flat surface using 'aqualarm' floor clips (CL-1) hot melt glued or screwed to the surface at 500 mm centres. (Do not rely on sticky back pads only)

**IMPORTANT NOTES;-**

- c. **Do not use metal ties or straps as they can damage the Detecting cable.**
- d. **Do not over tighten the cable ties.**
- e. **Detecting cable should never be installed between pipe-work and its insulation. It must be installed on the outside of any insulation finish.**
- f. **'aqualarm' WARNING LABELS (WL-1) should be fitted at 5m intervals along the entire length of all cables installed. Where cables go through walls etc. the WL-1 should be fitted either side of the wall.**
- v. **Oil / non conductive Point Detector (IRDi-24)**  
 Consists of 2 parts, an Infra-Red point Detector connected by a fly lead to a CDBi Module. The CDBi module can be mounted remotely with the Infra-Red Point Detector normally sited at the corners of an oil storage tank. Where it is to be used for other non-conductive liquids, it should be sited adjacent to the potential leak.
- vi. **Overflow Detector (OFDi-24)**  
 The Overflow Detector is used to detect water flowing through pipework. The detector is fitted with a 3/4" male thread to enable it to be fitted into a 'T' piece within the pipe-work. The long detecting probes should be cut to length on site to suit the insert.
- vii. **Float type Detector (FLi-24)**  
 The Float Detector is used in sumps & other areas where other types of Detectors can not practically be used.
- viii. **Refrigerant Gas Detector (RGi-24)**  
 The Refrigerant Gas Detector should be sited at a level below the equipment or pipe-work from which refrigerant gas can be expected to escape.
- ix. **3 Stage Temperature Detector (TDi-24)**  
 The Temperature Detector can be configured to give 1 x Low & 2 x High temperature alarms. The Detector should be sited within the risk area at a height of between 1.5 & 2 metres.

## **Section A ..... (cont)**

### **b. Description .....(cont.)**

#### **viii. Humidity Detector (HDI-24)**

*The Humidity Detector should be sited within the risk area at a height of between 1.5 & 2 metres.*

**(See page 17 to set Alarm level thresholds.)**

#### **ix. Water Leak Locating Module (ZLM-500)**

*The ZLM-500 Locating Module consists of 2 parts, a ZLM Locating Module plus modular lengths of Detecting Cable (CD-x) up to a maximum amount of 500 metres. (inc. the Leader Cable & any Jumper Cable). The ZLM-500 module should be mounted at the start with the Detecting cable installed in the areas to be monitored.*

#### **Leader / Jumper cables**

**NOTE: Only J.A.M. Ltd. Leader & Jumper Cables must be used.**

- i. The Leader cable (LS-LC) should be installed first. The bare end of the Leader cable, consisting of 2 cores, should be installed **ready to connect** into the ZLM-500 Module via the knockout provided and with a suitable cable gland to the terminals marked 'CD-X'.*
- ii. The cores can be connected to either terminal as there is no polarity.*
- iii. The connectorized end of the Leader cable (female) is to be connected to the first piece of Detecting cable (CD-x).*
- iv. Detecting cables (CD-x) & Jumper cables (LS-JC) are connectorized at both ends (one end female the other end male, the female end should always be at the furthest end of the piece of cable you have just installed). The Jumper cable (LS-JC) is to be used where it is required to connect Detecting cables (CD-x) installed in different areas.*
- v. Ensure all cables are installed Securely.**
- vi. The ZLM Module is now ready for Mapping.**

**(See page 20 for Mapping Procedure.)**

#### **Detecting cable.**

- i. CD-x (x = Length — 1, 2, 5 or 10 metres)**
- ii. Detecting cable (CD-x) should be installed using the following methods:-*
  - a. Clip to the underside of pipe-work using nylon type cable ties at 300 mm centres..*
  - b. Clip to the floor slab or other flat surface using 'aqualarm' floor clips (CL-1) hot melt glued or screwed to the surface at 500 mm centres. (Do not rely on sticky back pads only)*

**IMPORTANT NOTES;-**

**a. Do not use metal ties or straps as they can damage the Detecting cable.**

**- 7 -**

**Any combination of these can be used to make up the zone number required, i.e. if zone 9 is required, use dipswitch 4 and 1 together.  
(8 + 1 = 9)**

## **Section A ..... (cont)**

- b. *Description (Detecting Cable) .....(cont.)*
  - b. **Do not over tighten the cable ties.**
  - c. **Detecting cable should never be installed between pipe-work and its insulation. It must be installed on the outside of any insulation finish.**
  - d. **'aqualarm' WARNING LABELS (WL-1) should be fitted at 5m intervals along the entire length of all cables installed. Where cables go through walls etc. the WL-1 should be fitted either side of the wall.**
- 5. **Detector Dipswitchs.**
  - a. **Set-Up Procedure**
    - i. *Dipswitches are used to give the Detector an Identity Address in order that they can be identified by the Control Panel. Dipswitches are active when they are switched 'ON' in the 'UP' position.*
    - ii. **Dipswitch References (Dipswitch set to 'ON')**
      - Dipswitch 1 = Number 1*
      - Dipswitch 2 = Number 2*
      - Dipswitch 3 = Number 4*
      - Dipswitch 4 = Number 8*
      - Dipswitch 5 = Number 16*
      - Dipswitch 6 = Identifies Humidity Detector. (Factory set)*
      - Dipswitch 7 = Remote Mute Option (unused—set to 'OFF' position)*
      - Dipswitch 8 = Spare. (set to 'OFF' position)*
    - iii. *Dipswitches **must** be set prior to the detector being connected to the Control Panel.*
    - iv. *Dipswitch settings (addresses) will represent the Detector's location / zone identity. The higher the dipswitch setting number, the higher the zone allocated, regardless of the location of the detector within the string, for example:-*

## **Section A ..... (cont)**

### **5. Detector Dipswitch Set-Up ..... (cont)**

v. If an additional detector is added to the string, as shown in the **Dotted Box** and this new detector is set up as Zone 4 using dipswitch 3, the Control Panel would then recognise the detectors in the following order: Detector No.2 as Zone 1, Detector No.4 as Zone 2, Detector No.3 as Zone 3, the new Detector No.5 as zone 4 & Detector No.1 as Zone 5.

vi. **This is because the zones are allocated to the lowest dipswitch setting first.**

vii. Now, if the above example was on a 4 zone Control Panel and the customer tried to add a 5<sup>th</sup> detector to the system with the dipswitches set up as per the previous example, the Control Panel would actually ignore Detector Number 1 as this has the highest dipswitch setting. (Zone 5, with Dipswitches 1+3 set.) Therefore, to avoid confusion, it is strongly recommended to run the detectors with the dipswitches in numerical order along the string.

#### **b. Dipswitch effect on Set Up Procedure**

i. During the initial **Commissioning Set-Up** procedure, if all the dipswitches are set to **OFF** (dipswitch down) the result will be shown as '**0 Detectors**' found.

ii. If any 2 different types of detectors (I.e. Water, Refrigerant) are found with the same dipswitch setting, this will cause the system to identify **UNKNOWN DETECTORS** and the **Commissioning** will fail. it will eventually cause a **NETWORK FAIL** Alarm if saved.

**(See Sect. D3 for further information)**

**— DO NOT SAVE THIS SET UP. —**

iii. Using only the details shown in the **Solid Boxes**, the above example will result in the Control Panel recognising the installed detectors in the following order:-

Detector No.2 as Zone 1, Detector No.4 as Zone 2, Detector No.3 as Zone 3 and Detector No.1 as zone 4.

#### **c. Replacing a Detector after initial Commissioning.**

i. When replacing a Detector, you must ensure that the dipswitch settings for the new detector match that of the original unit. If the replacement detector has the same dipswitch setting as another detector already on the string, then all the detectors on the system will go into alarm. **(See Sect. C5 & D3 for further information)**



ii. If the replacement detector has a dipswitch setting higher than any other detector on the system, all existing detectors on the string after the location of the replacement detector will be identified by the Control Panel as 1 Zone number lower and this will not correspond with the Original 'As Installed' drawing.

### Dipswitch setting Check Sheet & CAN Address Ident.

Squares that are black, i.e. ■ represent the switch being 'ON' (in the 'UP' position). Should a Detector be a Humidity type, Dipswitch Number 6 will also be 'ON' (in the 'UP' position). This will be factory set.

Detector Zone To set detector As	Switch	Switch Setting	CAN Address Ident	Set <input checked="" type="checkbox"/>
Zone 1	Switch	On Off	<input type="checkbox"/> <input type="checkbox"/> <input type="checkbox"/> <input type="checkbox"/> <input type="checkbox"/> <input type="checkbox"/> <input type="checkbox"/> <input type="checkbox"/> 1 2 3 4 5 6 7 8	<input type="checkbox"/>
Zone 2	Switch	On Off	<input type="checkbox"/> <input checked="" type="checkbox"/> <input type="checkbox"/> <input type="checkbox"/> <input type="checkbox"/> <input type="checkbox"/> <input type="checkbox"/> <input type="checkbox"/> 1 2 3 4 5 6 7 8	<input type="checkbox"/>
Zone 3	Switch	On Off	<input checked="" type="checkbox"/> <input checked="" type="checkbox"/> <input type="checkbox"/> <input type="checkbox"/> <input type="checkbox"/> <input type="checkbox"/> <input type="checkbox"/> <input type="checkbox"/> 1 2 3 4 5 6 7 8	<input type="checkbox"/>
Zone 4	Switch	On Off	<input type="checkbox"/> <input type="checkbox"/> <input checked="" type="checkbox"/> <input type="checkbox"/> <input type="checkbox"/> <input type="checkbox"/> <input type="checkbox"/> <input type="checkbox"/> 1 2 3 4 5 6 7 8	<input type="checkbox"/>
Zone 5	Switch	On Off	<input checked="" type="checkbox"/> <input type="checkbox"/> <input checked="" type="checkbox"/> <input type="checkbox"/> <input type="checkbox"/> <input type="checkbox"/> <input type="checkbox"/> <input type="checkbox"/> 1 2 3 4 5 6 7 8	<input type="checkbox"/>
Zone 6	Switch	On Off	<input checked="" type="checkbox"/> <input checked="" type="checkbox"/> <input checked="" type="checkbox"/> <input type="checkbox"/> <input type="checkbox"/> <input type="checkbox"/> <input type="checkbox"/> <input type="checkbox"/> 1 2 3 4 5 6 7 8	<input type="checkbox"/>
Zone 7	Switch	On Off	<input checked="" type="checkbox"/> <input checked="" type="checkbox"/> <input checked="" type="checkbox"/> <input checked="" type="checkbox"/> <input type="checkbox"/> <input type="checkbox"/> <input type="checkbox"/> <input type="checkbox"/> 1 2 3 4 5 6 7 8	<input type="checkbox"/>
Zone 8	Switch	On Off	<input type="checkbox"/> <input type="checkbox"/> <input type="checkbox"/> <input checked="" type="checkbox"/> <input type="checkbox"/> <input type="checkbox"/> <input type="checkbox"/> <input type="checkbox"/> 1 2 3 4 5 6 7 8	<input type="checkbox"/>
Zone 9	Switch	On Off	<input checked="" type="checkbox"/> <input type="checkbox"/> <input type="checkbox"/> <input checked="" type="checkbox"/> <input type="checkbox"/> <input type="checkbox"/> <input type="checkbox"/> <input type="checkbox"/> 1 2 3 4 5 6 7 8	<input type="checkbox"/>
Zone 10	Switch	On Off	<input checked="" type="checkbox"/> <input type="checkbox"/> <input checked="" type="checkbox"/> <input checked="" type="checkbox"/> <input type="checkbox"/> <input type="checkbox"/> <input type="checkbox"/> <input type="checkbox"/> 1 2 3 4 5 6 7 8	<input type="checkbox"/>
Zone 11	Switch	On Off	<input checked="" type="checkbox"/> <input checked="" type="checkbox"/> <input type="checkbox"/> <input checked="" type="checkbox"/> <input type="checkbox"/> <input type="checkbox"/> <input type="checkbox"/> <input type="checkbox"/> 1 2 3 4 5 6 7 8	<input type="checkbox"/>
Zone 12	Switch	On Off	<input type="checkbox"/> <input type="checkbox"/> <input checked="" type="checkbox"/> <input checked="" type="checkbox"/> <input type="checkbox"/> <input type="checkbox"/> <input type="checkbox"/> <input type="checkbox"/> 1 2 3 4 5 6 7 8	<input type="checkbox"/>
Zone 13	Switch	On Off	<input checked="" type="checkbox"/> <input type="checkbox"/> <input checked="" type="checkbox"/> <input checked="" type="checkbox"/> <input type="checkbox"/> <input type="checkbox"/> <input type="checkbox"/> <input type="checkbox"/> 1 2 3 4 5 6 7 8	<input type="checkbox"/>

## Dipswitch setting Check Sheet ..... cont

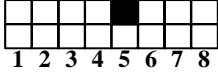
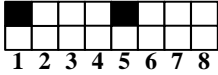
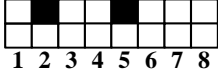
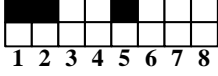
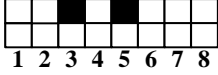
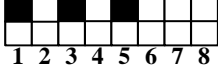
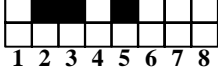
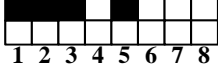
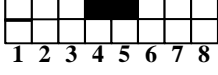
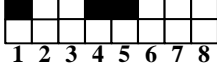
Detector Zone To set detector As			Switch Setting	CAN Address Ident	Set
					<input checked="" type="checkbox"/>
Zone 14	Switch	On Off		0E H	<input type="checkbox"/>
Zone 15	Switch	On Off		0F H	<input type="checkbox"/>
Zone 16	Switch	On Off		10 H	<input type="checkbox"/>
Zone 17	Switch	On Off		11 H	<input type="checkbox"/>
Zone 18	Switch	On Off		12 H	<input type="checkbox"/>
Zone 19	Switch	On Off		13 H	<input type="checkbox"/>
Zone 20	Switch	On Off		14 H	<input type="checkbox"/>
Zone 21	Switch	On Off		15 H	<input type="checkbox"/>
Zone 22	Switch	On Off		16 H	<input type="checkbox"/>
Zone 23	Switch	On Off		17 H	<input type="checkbox"/>
Zone 24	Switch	On Off		18 H	<input type="checkbox"/>
Zone 25	Switch	On Off		19 H	<input type="checkbox"/>

## Section B

### Control Panel.

#### 1. Start-Up & Commissioning Procedure.

- i. On completion of the Installation of all Network Cables & Detectors, use the following procedure to Start-Up the system :-
- ii. Ensure that the Network Cable is connected to the Control Panel terminals marked **CAN** V+, V-, Hi, Lo. via a suitable cable entry gland.
- iii. **Cause a competent qualified person to connect the Battery Back-Up leads to the correct terminals of the sealed Lead Acid Batteries and the Control Panel to the Mains Power supply as described in Section 'A'.**  
(See also page 33 Control Panel Terminals.)
- iv. **Close & Lock the Control Panel door & Switch on the Mains Power supply.**
- v. The LCD screen will now DISPLAY the following:-

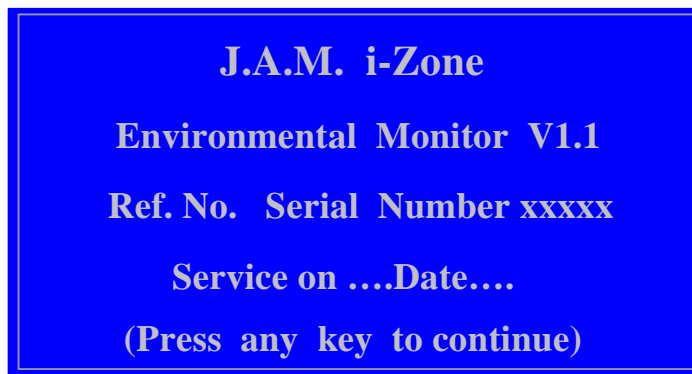

- vi. **Press any button to continue with the 'COMMISSIONING' procedure, the LCD screen will now DISPLAY the following:-**



## Section B ..... (cont)

- vii. To continue with the 'COMMISSIONING' procedure **Press** the button corresponding to the '**RETURN**' symbol. The LCD screen will now **DISPLAY** the following:-

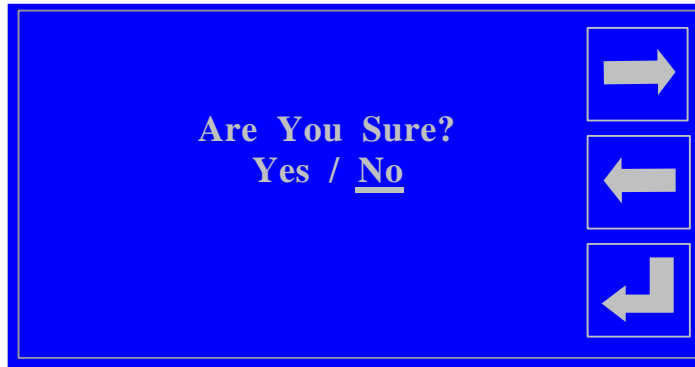

- viii. **Press** the '**ARROW**' keys to place the underline either under the **Yes** or **No**. **IF Yes** the LCD will now **DISPLAY** the following:-



- ix. The Control Panel will now automatically search for any sensor connected to the system & record & store the type & its location. The system will only record up to the maximum of sensors allowed to be connected to the system. (i.e. — an **i-Zone 5** system will only record up to 5 sensors — an **i-Zone 10** will only record up to 10 sensors etc.) When the system has recorded all the information **Press** the button corresponding to the '**SAVE**' key. A long bleep will be heard until the system has recorded all the commissioning information. The LCD screen will now display the General Screen.

**Section G ..... (cont)**

**4. Relay Pack - SWRi-8 ..... (cont)**

# PLEASE NOTE - You cannot mix items i. & ii above, it 's either or.



**SWRi-8 Dedicated Relay Pack. (Circuit Board Layout)**

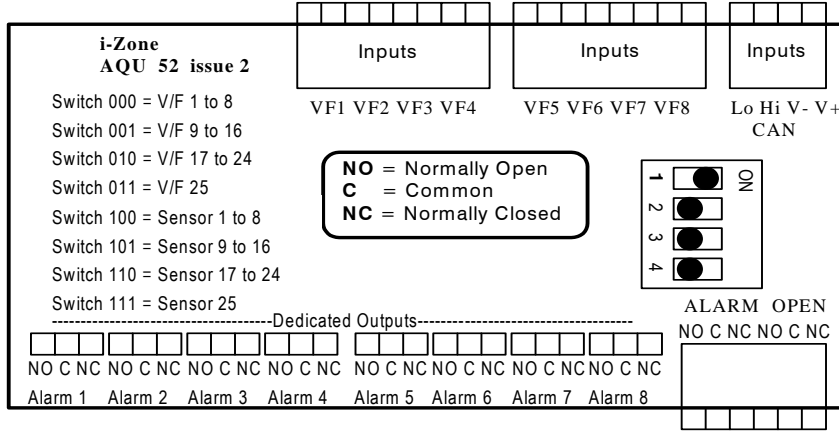

iii. **Maximum rating for Dedicated outputs = 16 Amp @ 240 volt AC.**

iv. **VF Inputs are Volt Free only.**

v. A SWRi-8 relay pack is connected to the Control Panel in the same manner as a Detector (via the 'CAN' connector) and can be installed anywhere along the string of Detectors, (capable of giving outputs for up to 8 detectors per pack) as shown below:-

**SWRi-8 Dedicated Relay Pack. (Where to position in system)**

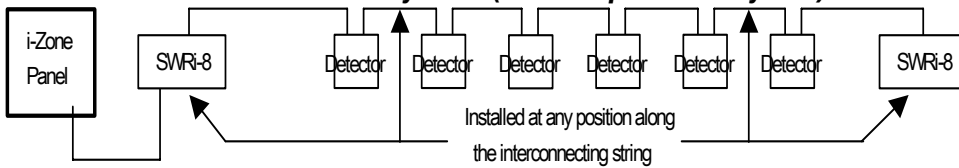

## Section B..... (cont)

### 2. Set-Up Time & Date.

- i. Press the button corresponding to the **UP 'ARROW'** key, until the LCD Screen displays the following:-



- ii. Press the button corresponding to the **'ENTER'** key. The LCD screen will display the following:-

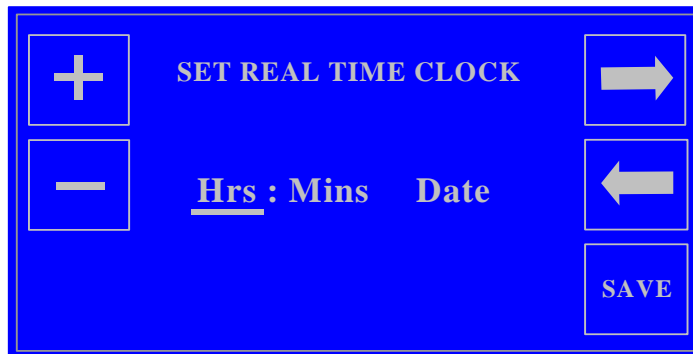

- iii. The Hours will be underlined.  
iv. Using the buttons corresponding to the '+ / -' keys, set the hours.  
v. Continue using the buttons corresponding to the **'ARROW'** keys, to underline the Minutes, then the date. Use the '+ / -' keys to set the Minutes then the Date. When the correct time & date has been entered, **Press** the button corresponding to the **'SAVE'** key. This will save the time & date and the screen will revert back to the General Screen.

## Section C.

### Detector Set-Up.

1. Important Information regarding thresholds of the Refrigerant Gas Detector

## Section C..... (cont)

- i. *Our Refrigerant Gas Detectors use a Semiconductor based sensor head to monitor the air for the presence of refrigerant gas. These heads need to run warm to enable them to function.*
- ii. *Each detector has a **'Running Threshold'**. This is represented on the Control Panel display by a numeric number that is adjacent to the words 'Refrigerant Gas', when you press the 'SET ZONE' button, after you have scrolled to a zone that has a Refrigerant Gas Detector attached. (See Section C. Setting Detector Sensitivity). The **'Running Threshold'** of a Detector will fluctuate as it is affected by the changing conditions of its environment. It is very likely that each Detector will settle to a different **'Running Threshold'**, due to the differences in the local environment around each Detector and electronic component tolerances. Each Detector also has an **'Alarm Threshold'**. This is the level at which the detector will activate an alarm condition on the Control Panel. It is recommended that the **'Alarm Threshold'** be set 100 points below the **'Running Threshold'** that each Detector settles at.*
- iii. *Semiconductor sensor heads are affected by changes in Humidity and Temperature, therefore if the criteria of the environment where the Detector is located changes, i.e when the building changes from a Building site environment to an occupied working environment, then it is very likely that the **'Running Threshold'** will change (+/-) as well. If this occurs the **'Alarm Threshold'** will need to be adjusted to keep the 100 point difference between the **Running and Alarm Thresholds**.*
- iv. *In extreme cases where the **'Running Threshold'** does not allow a 100 point difference to the **'Alarm Threshold'**, i.e. **'Running Threshold'** only reaches 55 points, the minimum level you should set the **'Alarm Threshold'** is 5 points. In these cases we would recommend increasing the amount of **'ALARM SAMPLES'** therefore making the system check a Detector that has gone into an alarm, a second, third or fourth time etc. before actually triggering the **ALARM** status at the Control Panel.*
- v. *Detectors **must not** be sited within the cold air flow or return air flow of an AC unit, as this will prevent the detector from reaching a stable threshold.*
- vi. *Semiconductor Sensor heads are affected by CFC & HFC's. These are present in most aerosol propellants, photocopier toner and other sources. If you have a detector located within a copy room or within a room that receives a heavy clean (i.e. heavy use of cleaning sprays) etc, then the Detector could be triggered into a 'False Alarm'. By increasing the amount of **'Alarm Samples'** of that particular detector, you should be able to eliminate these issues.*

## Section C.

### 2. Detector Sensitivity

- i. Each detector has a '**Running Threshold**' that dictates the setting of the '**Alarm Threshold**'. The '**Running Threshold**' is identified by a numeric reading adjacent to the detector type shown on the LCD. With each type of detector located with an 'ideal environment' you should be looking to achieve the '**Running Thresholds**' as shown below:-

	<b>Running Threshold Laboratory Conditions</b>	<b>Set Alarm Threshold To:-</b>	<b>Default Alarm Sample</b>	<b>Fail Amplitude</b>
<b>Water Detector (cable)</b>	45/46	2	0	Low
<b>Water Detector (others)</b>	45/46	15	0	Low
<b>Oil type Detector</b>	5/15	40	0	High
<b>Refrigerant Gas Detector</b>	Running threshold Varies due to environmental conditions. Set Alarm to 100 below the threshold displayed. If threshold shows below 100 set Alarm to 50 below.		0	N/A
<b>Temperature Detector</b>	N/A	As req'd	N/A	N/A
<b>Humidity Detector</b>	N/A	As req'd	N/A	N/A

- ii. The '**Alarm Threshold**' for each type of Detector will be set to the Default Setting shown in the table above. You may wish to change the '**Alarm Threshold**', due to the site conditions affecting the '**Running Threshold**' or to make the Detector more or less sensitive. Decreasing the gap between the '**Running Threshold**' and the '**Alarm Threshold**' will make the Detector more sensitive and by increasing the gap will make the Detector less sensitive. To adjust the Detector Alarm thresholds please refer to — **Setting Detector Alarm Thresholds**.
- iii. Temperature and Humidity Detectors do not have an optimum '**Running Threshold**' or '**Alarm Threshold**' as these settings are totally dictated by the environment that the Detector is located in and the alarm level that the client / user wishes the Detectors to be activated at.
- iv. Giving the '**Alarm Sample**' a Higher Number will cause the System to Double Check, Treble Check etc. the status of the detector (depending on the number choosen), before activating an '**Alarm State**'. So a minute splash of water will possibly have time to dry out and the Control Panel will not activate an '**Alarm state**'.

## Section C. .... (cont)

### 3. Setting Detector Alarm Thresholds.

- i. Once Commissioning has been carried out you can then set-up the individual Detectors to the Client's parameters. The General LCD screen will be displaying the following:-



- ii. Press the button corresponding to the **UP 'Arrow'** Key to scroll to the Detector you wish to change the Clients parameters. The LCD screen will display the following:-

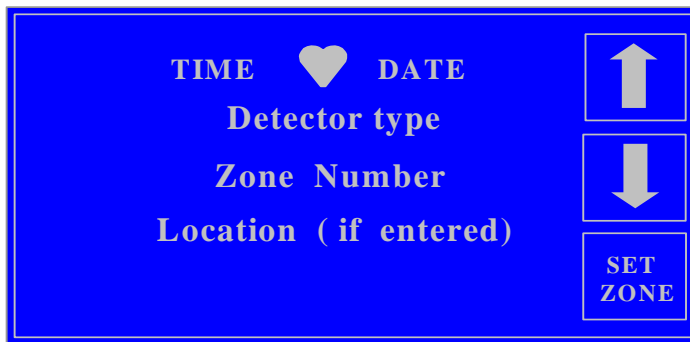

- iii. Press the button corresponding to the **'Set Zone'** key. This will take you into the Detector **'Set-up'** page. Depending on the type of Detector installed at the particular location, the LCD screen will now display the following **'Set-Up'** information:-

**Separate 'Set-Up' screens will be displayed for the following detectors:-**

- |   |   |                          |
|---|---|--------------------------|
| <b>CDBi</b> - Water detection Cable type.                     | } | Same Screen but requires |
| <b>STDi, OFDi &amp; FLi</b> - Other types of Water detection. | } | you to change certain    |
| <b>IRDi</b> - Oil, non-conductive liquids.                    | } | settings.                |
| <b>ZLM-500</b> - Water detection Locating Module.             |   |                          |
| <b>RGi</b> - Refrigerant Gas.                                 |   |                          |
| <b>TDi</b> - Temperature.                                     |   |                          |
| <b>HMi</b> - Humidity.  |   |                          |

## Section C ..... (cont)

### 3. Setting Detector Alarm Thresholds ..... (cont)

- iv. Using the buttons corresponding to the 'Arrow' Keys, scroll the box to the parameter you wish to change.
- v. Using the buttons corresponding to the '+ & -' Keys, change the value to the required value. On completion of all changes **PRESS** the button corresponding to the 'Save' key. Your new values will now be saved into the Control Panel's memory.

#### a. Liquid Detectors

+	Liquid Detector Setup	↑
	Alarm Sonar 2	
-	Alarm Samples 0	↓
	Fail Low Amplitude	
		SAVE

*CDBi* - Detectors should be set as seen above.

**All other Liquid Detectors** - should be set as above but with the 'Alarm Sonar' set at 15.

*IRDi* - Detectors should be set as above but with the 'Amplitude' set to **Fail High**.

#### b. Refrigerant Gas Detectors

+	Refrigerant Gas 193	↑
	Alarm Below 5	
-	Alarm Samples 0	↓
		SAVE

Set **Alarm** value at 100 below refrigerant gas value shown. If refrigerant gas value shown is below 100, set **Alarm** value to 50 below.

## Section C ..... (cont)

### 3. Setting Detector Alarm Thresholds ..... (cont)

#### c. Temperature Detectors

*High Level 1* will 'Alarm' when temperature rises to the value set in this box.

*High Level 2* will 'Alarm' when temperature rises to the value set in this box.

*Low Level* will 'Alarm' when temperature drops to the value set in this box.

Temperature Alarms	
+	99 °C High Level 2
-	66 °C High Level 1
	02 °C Low Level
SAVE	

#### d. Humidity Detectors

*High Level 1* will 'Alarm' when humidity rises to the value set in this box.

*High Level 2* will 'Alarm' when humidity rises to the value set in this box.

*Low Level* will 'Alarm' when humidity drops to the value set in this box.

Humidity Alarms	
+	99 RH High Level 2
-	66 RH High Level 1
	02 RH Low Level
SAVE	

### 4. Mapping Procedure for ZLM-500 Module (SEE PAGES 44 & 45 for MAPPING RESULTS SHEET)

- i. Using the Mapping Tool provided, carry out the following:-
- ii. Starting at the first joint between the leader cable LS/LC & the first piece of detecting cable (CD-x), open the joint. The 'Alarm Horn' will sound and the LCD screen will DISPLAY the following:-

## Section C ..... (cont)

### 4. Mapping Procedure for ZLM-500 Module ..(cont)



**Note this Reading on your Mapping Results Sheet.**

- iii. Connect the Mapping Tool lead into the Leader cable and the Detecting cable into the other end of the Mapping Tool. **Press** the button corresponding to the '**Reset**' key, the LCD screen will now revert to the General Screen.
- iv. **Press & hold down the Button** on the top of the Mapping Tool until the '**Alarm Horn**' sounds. The LCD screen will now display the following:-

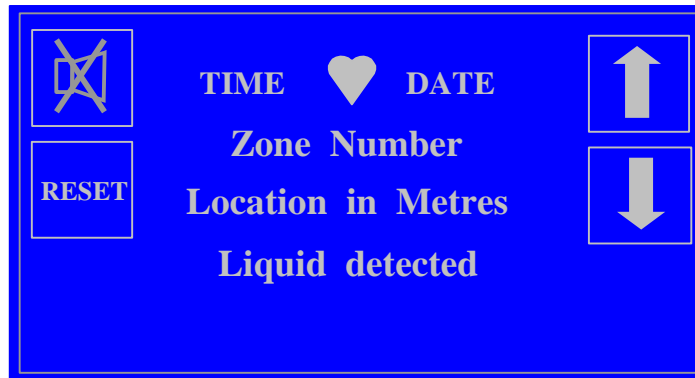

**Note this Reading on your Mapping Results Sheet..**

- v. Disconnect the Mapping Tool & re-instate the joint. **Press** the button corresponding to the '**Reset**' key, the LCD screen will now revert to the General Screen. – **Go to the next joint.**

## **Section C ..... (cont)**

### **4. Mapping Procedure ..... (cont)**

- vi. *Disconnect this joint & **CONTINUE MAPPING EACH JOINT AS DESCRIBED IN the Paragraphs above UNTIL ALL JOINTS HAVE BEEN MAPPED & RECORDED (including the End of Line joint EOL).***
- vii. *The figures recorded will form the basis for preparing the **'Locating Module Map'**.*
- viii. ***THE MODULE IS NOW SET & READY FOR USE.***

### **5. Hot Swapping of Electronic Components.**

#### **a. Definition.**

- i. *The definition of the term 'HOT SWAPPING' relates to the changing of any electronic component of the system. I.e. printed circuit boards , detectors, interconnecting cables etc on the CAN network when the Control Panel is powered (including the system batteries or UPS supplies) and is in a live status.*
- ii. *The CAN Network will not support 'HOT SWAPPING'. If you change over a detector or other component for any reason whilst the system is live & running, the CAN Network will be corrupted. This will result in various system failures, I.e. the LCD Display will go blank & the system software will freeze. ( the display will not change regardless of pressing the buttons etc.) Network Failures or to the extreme where the CAN Network can be blocked (frozen) and will no longer receive or send Data. However the Control Panel will still show a 'CLEAR' status, as the last data received was within acceptable parameters and it cannot refresh as the CAN Network is blocked.*

#### **b. Remedy.**

- i. *Should you inadvertently carry out a 'HOT SWAP', it is essential that you carry out a system REFRESH using the following procedure:-*
- ii. *Switch OFF the Mains Power Supply. This will cause a 'Mains Fail' Alarm, which cannot be Muted.*
- iii. *Open the Control Panel door.*
- iv. *Remove the CAN Network Cable by pulling the GREEN Molex Plug from the bottom left hand corner of the Main / Top PCB.*
- v. *This will cause a 'Network Fail' on all Detectors previously connected to the system. I.e. if 6 Detectors were connected then 6 alarms will be generated. After the final Detector Alarm been generated, PRESS the 'MUTE' button to silence the Alarm Horn.*
- vi. *Using the UP arrow button on the top right of the LCD Display Screen, scroll through the Menue until you reach 'PRESS ENTER TO COMMISSION I-ZONE SYSTEM'. - **PRESS ENTER** -*
- vii. *Using the middle button on the right hand side of the LCD Display Screen, move the cursor under the word 'YES'. - **PRESS ENTER** -*

## Section C ..... (cont)

### 5. Hot Swapping of Electronic Components.

#### b. Remedy..... (cont)

- viii. The System will start a scan and will finish with 'NO DETECTORS FOUND' - **PRESS 'SAVE'** -
- ix. Remove the BLUE battery lead from Battery NO 2. This will remove all power from the system and the LCD screen will go blank.
- x. Wait 30 seconds. Then re-connect the CAN network cable by re-inserting the GREEN mox plug into the mox socket located in the bottom left hand corner of the Main /Top PCB.
- xi. Carefully re-connect the BLUE battery lead to the BLUE terminal on Battery NO 2. (WE WOULD ADVISE THAT THE BATTERY TERMINAL IS RE-CONNECTED IN A SWIFT MOTION TO PREVENT ARCHING).
- xli. Close and lock the Control Panel door.
- xliii. **'Switch On'** the Mains Power supply.
- xliii. The Control Panel will display the factory setting information. I.e. serial number, etc. **PRESS ANY KEY TO CONTINUE.**
- xv. The LCD display will now show the option 'PRESS ENTER TO COMMISSION I-ZONE SYSTEM' - Press 'ENTER'.
- xvi. Using the middle button on the right hand side of the LCD display, move the cursor to the left and under the word 'YES'. - Press 'ENTER'.
- xvii. The system will now re-scan and find all connected detectors.
- xviii. Press 'SAVE' to store this information.

## Section D.

### Control Panel Functions.

#### 1. What to do if an Alarm sounds.

##### a. Alarm. (Detectors)

- i. In the event of an 'Alarm' the LCD screen will display the following:-

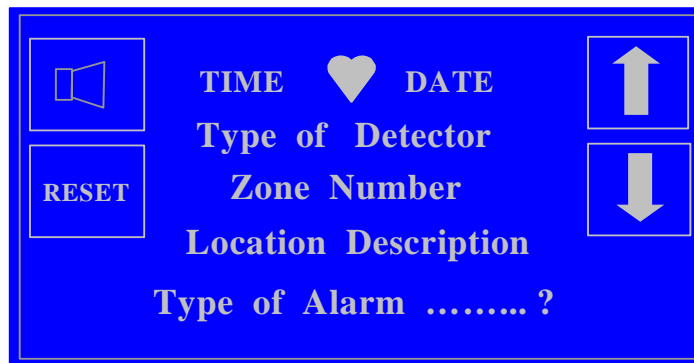

## Section D.

### Control Panel Functions.

#### 1. What to do if an Alarm sounds.

##### a. Alarm. (Detectors) ..... (cont)

- ii. Press the button corresponding to the '**HORN**' symbol, the alarm horn will cease to sound & the LCD screen will now display the following:-

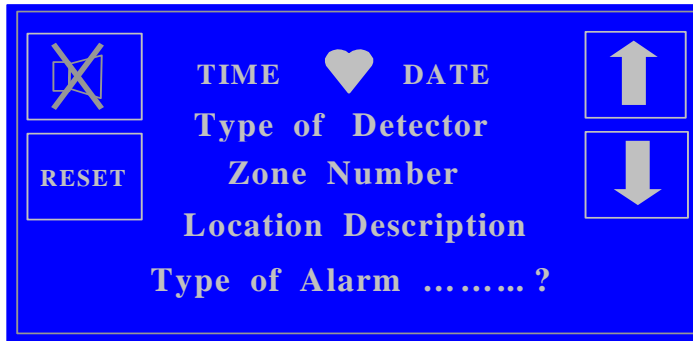

- ii. **Attend to the reason giving rise to the Alarm.**  
iv. After attending to the reason for the alarm, reset the system by **pressing** the button corresponding to the '**RESET**' key. The LCD Screen will revert to the General Screen and the system will return to Normal Operation.

# **NOTE – Following a Water Leak, the Detecting Cable should be dried using a Clean Dry cloth. If the Detecting Cable is left to dry of its own accord, ensure that an adequate air flow is available to dry it. This could take up to 24 hours (depending on the air flow available, temperature & extent of the water leak). Contamination of Detecting Cable may occur after a water leak (especially if it is allowed to dry of its own accord) if the floor area where it is installed is dirty or dusty. This may cause the cable to short circuit because of a 'Trace Path' of congealed dust particles or dirt. This will stop the system from being able to be 'RESET'.**

##### b. Open Circuit. (Detectors)

- i. Should damage occur or a joint between the CDBi Detector Module & Detecting cables become parted, an '**Open Circuit**' alarm is activated.  
ii. The LCD Screen will show the '**Alarm**' as '**Detecting Cable O/C**'.  
iii. Press the button corresponding to the '**MUTE**' key and the alarm horn will cease to sound.

## Section D ..... (cont)

### 1. What to do if an Alarm sounds ..... (cont)

#### b. Open Circuit. (Detectors) ..... (cont)

iv. **Attend to the reason giving rise to the Alarm.**

v. After attending to the reason for the alarm, reset the system. **Press** the button corresponding to the 'RESET' key. The LCD Screen will revert to the General Screen and the system will return to Normal Operation.

# **NOTE – The most common cause of an 'Open Circuit' alarm is caused by Engineers who are working in the area of the alarm. They may have caused damage to the detecting cable or opened a joint whilst carrying out other duties or works. Always be aware of any works being carried out in the vicinity of your Water Leak detection System.**

### 2. Water Leak Locating Module (ZLM-500)

#### a. Liquid Detected Alarm

i. On detecting the presence of water the LCD screen will display the following:-

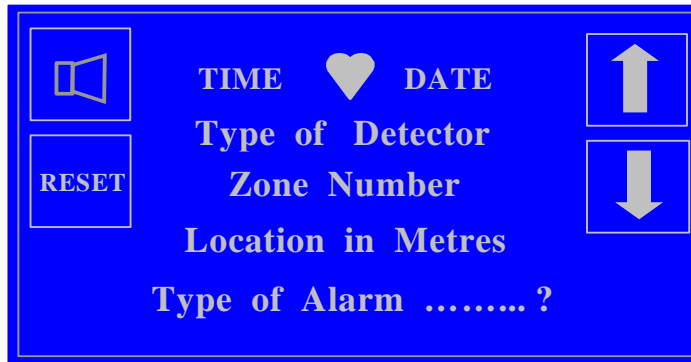

ii. **Press** the button corresponding to the 'HORN' symbol, the alarm horn will cease to sound & the LCD will now display the following:-

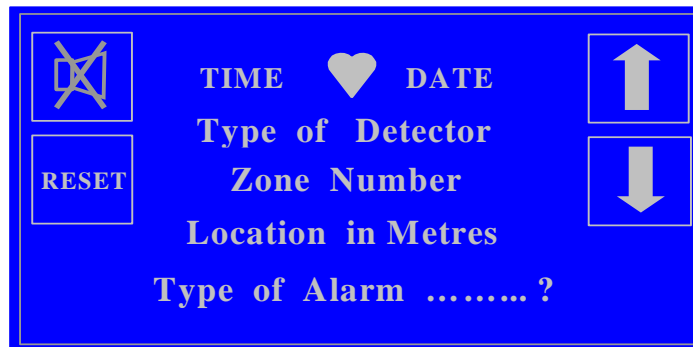

## **Section D ..... (cont)**

### **1. What to do if an Alarm sounds ..... (cont)**

#### **2. Water Leak Locating Module (ZLM-500) ... (cont)**

##### **a. Liquid Detected Alarm ..... (cont)**

- iii. Take **NOTE of the LOCATION READING** displayed. Check this reading against the **Locating Module Map** to locate the **'Water Detected'**.
- iv. After attending to the reason for the alarm, reset the system by **pressing** the button corresponding to the **'RESET'** key. The LCD screen will revert to the General Screen and the system will return to Normal operation.
- v. Should the system re-alarm within 30 seconds & display the same or similar Location Reading, this will indicate that the Detecting cable has not dried or that the water is still present.
- vi. If a vastly different Location Reading is displayed this will indicate that a further water contact has been made.
- vii. Carry out the above procedures again until the LCD Screen reverts to the Normal Operation Screen.

##### **b. Open Circuit.**

- i. Should damage occur or a joint between Leader, Detecting or Jumper cables become parted, an **'Open Circuit'** alarm is activated.
- ii. The LCD Screen will display as item ii. above.
- iii. The 'Alarm Horn' will sound.
- iv. **Press** the button corresponding to the **'MUTE'** key, **take NOTE of the LOCATION READING displayed**, check this against the **Locating Module Map** to locate the **'Open Circuit'**.
- v. After attending to the reason for the alarm, reset the system by **pressing** the button corresponding to the **'RESET'** key. The LCD screen will revert to the General Screen and the system will return to Normal operation.

##### **c. Network Fail.**

- i. A **'NETWORK FAIL'** alarm will be displayed if the CAN network cable has been disconnected from the Control Panel or from any of the installed Detectors. Should this occur, the Alarm Horn will sound and the LCD display will now display the following:-

## Section D ..... (cont)

1. **What to do if an Alarm sounds ..... (cont)**
3. **Network Fail ... (cont)**

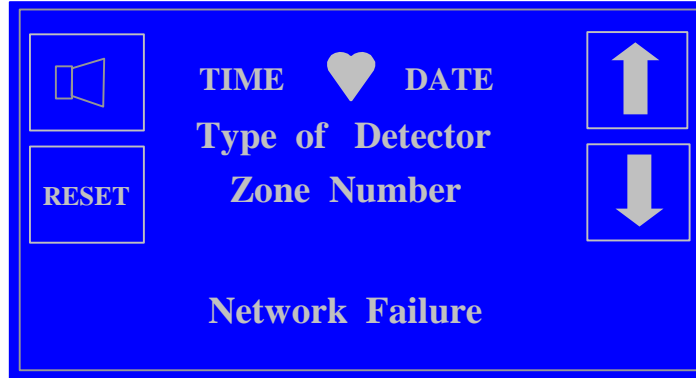

- ii. *You will need to rectify the break in the Network Cable before you can Re-Set the system to clear this alarm condition.*
  - iii. *However, the system will also use the '**NETWORK FAIL**' alarm condition as a generic alarm. Should the Network fail for any other reason, such as corrupt data caused by 'Hot Swapping' (see Sec C5) or detectors sharing dipswitch addresses (see Sec.A 5 ) etc.*
  - v. *Should the above sections not remedy your Network Fail alarm conditions, you will need to follow the Commissioning procedure (see Sec, B page 12 ) introducing 1 Detector at a time to the system network.*
- 3. Mains Fail.**
- i. *If the Mains Power fails, the LCD Screen will display the following:-*

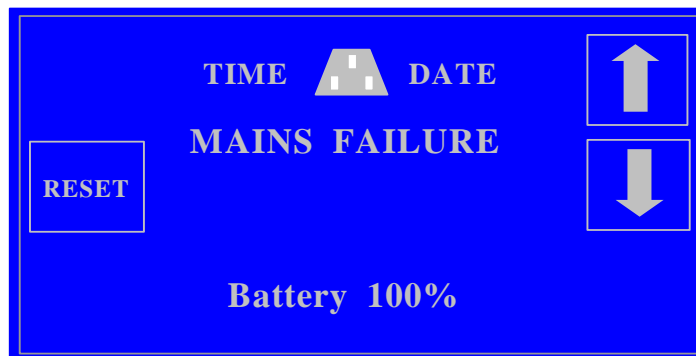

## Section D ..... (cont)

### 1. What to do if an Alarm sounds ..... (cont)

### 2. Water Leak Locating Module (ZLM-500) ... (cont)

### 3. Mains Fail. .... (cont)

- i. If the Mains Power fails, the LCD Screen will display the following:-
- ii. This will also cause the '**Mains Fail**' relay to energise and the system will switch automatically to Battery Back Up. The LCD Screen will display a pulsing plug & show the percentage **Life State** of the **Batteries**. When the **Life State** of the Batteries are approximately **10%** the Battery Fail relay will de-energise & the System will **Shut Down**.

### 4. Battery Fail.

- i. Should the Batteries Fail or become disconnected the LCD Screen will display the following:-

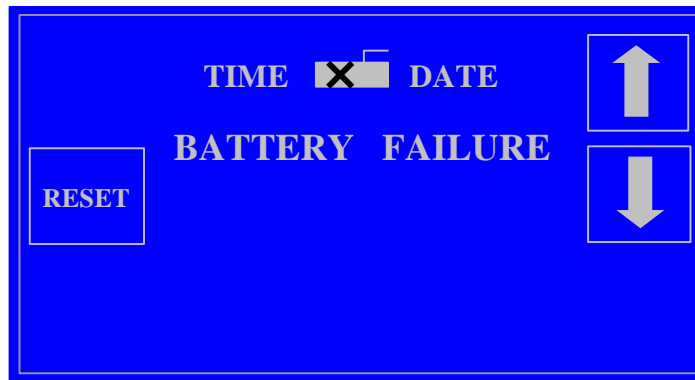

- ii. This will also cause the '**Battery Fail**' relay to energise. The LCD Screen will display a pulsing battery with a **CROSS** through it and a beep will be heard **every 75 secs.** whilst the batteries are in a '**Battery Fail**' state. After a short period of time the LCD screen will change to the General Screen. It will continue to display the '**BATTERY FAIL**' symbol.
  - iii. When the cause of the 'Alarm' has been dealt with **PRESS** the button corresponding to the '**RESET**' button. The LCD screen will revert to the General Screen and the system will return to normal operation.
- ### 6. Mute & Reset Keys.
- i. **Pressing** the button corresponding to the '**MUTE**' key, will cause the **alarm horn** to cease sounding & the Screen will display the following:-

## Section D ..... (cont)

1. **What to do if an Alarm sounds ..... (cont)**
2. **Water Leak Locating Module (ZLM-500) ... (cont)**
6. **Mute & Reset Keys.... (cont)**

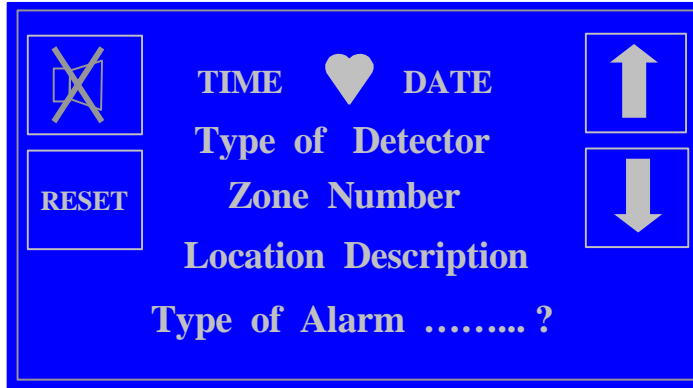

- This operation should be used on all occasions to 'MUTE' the sounder.*
- ii. **Pressing** the button corresponding to the 'RESET' key will cause the System to 'RESET'. This should always be used to 'Reset' the system following the clearance of an alarm condition. The LCD screen will now revert to the General Screen and the system will return to normal operation.

### 7. **View 255 Event Record Log.**

**# NOTE - After 255 events the 256th. event will overwrite & replace the 1st event & so on.**

- i. **Press** the button corresponding to the 'VIEW LOGS' key. The LCD screen will now DISPLAY the following:-

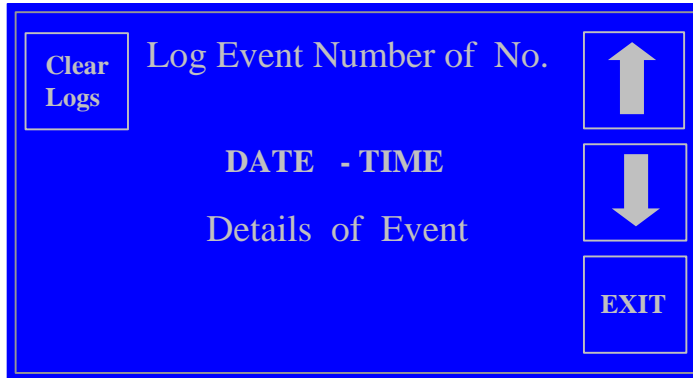

## Section D ..... (cont)

1. **What to do if an Alarm sounds ..... (cont)**
  2. **Water Leak Locating Module (ZLM-500) ... (cont)**
  7. **View 255 Event Record Log. ... (cont)**
- ii. Scroll through the Events using the buttons corresponding to the '**ARROW**' keys. To return to the General Screen **Press** the button corresponding to the '**EXIT**' key.
  - iii. To **CLEAR** all the Log Events from the Memory **Press** the button corresponding to the '**Clear Logs**' key. The LCD screen will now display the words '**LOGS CLEARED**'.
  - iv. After a short period of time the LCD will revert to the General Screen.

## Section E

### Control Panel Outputs.

#### 1. Relays.

The Control Panel has the following dedicated relay outputs each with a set of 'Clean Contacts' for remote signalling:-

<u>OUTPUT</u>	<u>TERMINALS MARKED</u>
Detector Alarm	'Alarm' - N.C. / C / N.O.
Interconnecting Cable Alarm	'Network Fail' - N.C. / C / N.O.
Mains Failure Alarm	'Mains Fail' - N.C. / C / N.O.
Battery Failure Alarm	'Batt Fail' - N.C. / C / N.O.
Service Alarm	'Service' - N.C. / C / N.O.

**N.C = Normally Closed. – C = Common. – N.O= Normally Open**

**All the above outputs are via a 'Clean Set' of Contacts with a Maximum rating of 3 amp at 30 volts D.C. or 125 volts A.C.**

<u>OUTPUT</u>	<u>TERMINALS MARKED</u>
Remote Sounder	'Sounder' - V+ / V-
Remote Beacon	'Beacon' - V+ / V-

**For connection to J.A.M. Sounder & Beacon only.**

**Beacon output is also used for the J.A.M. Repeater Panel.**

**Powered at 12 volts with a Maximum 10 amp rating.**

#### 2. RS 485

<u>OUTPUT</u>	<u>TERMINALS MARKED</u>
Building Management	'B.M.C.' - A / B / C

## Section F

### Care of Detecting Cables & Maintenance

#### 1. Care of Detecting Cables

- i. For the Detector to work, water must be able to penetrate the Detecting Cables. The following list of substances (although not exhaustive) will have a detrimental effect on the performance of Detecting cables & will cause continual un-wanted Alarms.  
**Fizzy Soda, (coca-cola etc) Coffee, Tea & Chocolate Drinks, Chemical Cleaning Agents both Wet or Dry, Photocopier, Printer Toners, Mastics & Sealants, Plumbing, Heating & A.C. lubricants, Glycol, Builders Rubble & Dust.**
- ii. All the above substances will cause an '**Alarm**' state. If allowed to dry without attendance a Trace Path (contamination) may occur & the '**Alarm**' state will not be able to be cleared or the system '**Reset**'. Contaminated cable should be removed, cleaned & allowed to dry before replacing back into service. If after cleaning the cable the Detector will not '**Reset**', **the cable must be replaced.**

**Damaged cable must always be replaced.**

- # **NOTE – Following a Water Leak, the Detecting Cable should be dried using a Clean Dry cloth. If the Detecting Cable is left to dry of its own accord, ensure that an adequate air flow is available to dry it. This could take up to 24 hours (depending on the air flow available, temperature & extent of the leak). Contamination of Detecting Cable may occur after a water leak (especially where it is allowed to dry of its own accord) if the floor area where it is installed is dirty or dusty. This may cause the cable to short circuit because of a 'Trace Path' of congealed dust particles or dirt. This will stop the system from being able to be 'RESET'**

#### 2. Maintenance.

- i. Although the system is relatively maintenance free, it is recommended that it should be checked fully at least ONCE each year. Should an alarm occur which you cannot clear by the method described in this Manual or you are unsure of the operation of any part of the system, please contact your local '**aqualarm**' '**i-Zone**' Agent or direct to **J.A.M. Limited** who will be pleased to give you assistance.
- ii. **J.A.M. Limited & their authorised Agents are able to offer you a comprehensive Maintenance Contract to look after your 'i-Zone' system on a 1, 2, or 4 visit programme each year. For information please contact the Authorised Agent listed on the back of this booklet or directly to J.A.M. Limited**

## **Section F ..... (cont)**

### **Care of Detecting Cables & Maintenance ..... (cont)**

#### **1. Care of Detecting Cables ..... (cont)**

#### **2. Maintenance ..... (cont)**

- iii. Your system is fitted with a '**Mains Fail**' Battery Back-Up system in the form of automatic re-chargeable Batteries They should give you a trouble free life of between 3 & 5 years (dependant on use).
- iv. When Maintenance is due the following screen will be displayed:-



- v. The 'Spanner' will pulse and a 'Bleep' sound will be heard.

### **FOR SERVICE**

**Telephone the number displayed  
OR contact J.A.M. Limited.**

**Tele: 44 (0) 1268 777222  
Fax: 44 (0) 1268 777221  
E-mail: [jam.ltd@virgin.net](mailto:jam.ltd@virgin.net)**

## Section G

### 1. Control Panel Terminals

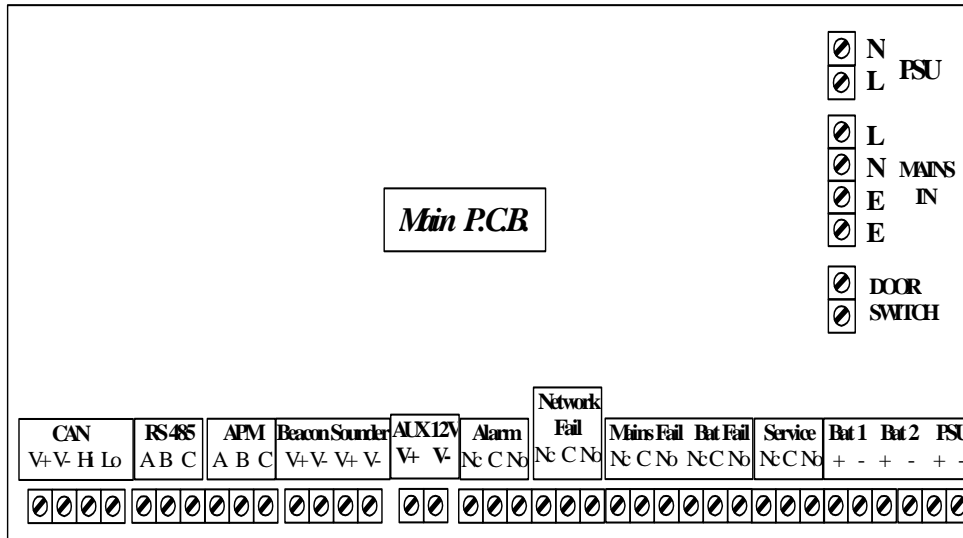

### BATTERY CONNECTIONS

#### MOST IMPORTANT

The RED battery lead (labelled Battery 1 ) must be connected to the RED terminal on Battery 1.

The BLUE battery lead (labelled Battery 2 ) must be connected to the BLUE terminal on Battery 2.

The BLACK lead (labelled Link) must be connected to the BLUE terminal on Battery 1 and to the RED terminal on Battery 2.

### 2. Ancillary Equipment

i. The following 'aqualarm' equipment is available to be connected directly to the complete range of 'i-Zone' Control Panels:-

- Repeater Panel (RP-1) - **Connect to Beacon V+ / V- & Sounder V+ / V-**
- Beacon & Sounder (B+S-1) - **Connect to Beacon V+ / V- & Sounder V+ / V-**
- Auto-dialler (SD-2) - **Connect to Beacon V+ & AUX 12 V V+ / V-**
- Auto-Text dialler (SMS-1) - **Connect to Beacon V+ & AUX 12 V V+ / V-**

## Section G ..... cont

### 3. Power Booster Box - PB-24

- i. The Power Booster Box (PB-24) must be used as follows:-  
Where an i-Zone 15, 20 or 25 system is being installed and the the Detectors are all Refrigerant Gas type (RGI-xx) a PB-24 Power Booster Box must be used to accommodate the amount of Power the RGI-xx Detectors require. (RGI-xx Detectors draw a large amount of power to keep the sensing heads hot.)  
**Note: The PB-24 is only required where all the Detectors on the system are RGI-xx type & the quantity exceeds 10.**
- ii. The PB-24 must be installed at the end of the string of RGI-xx Detectors and in the manner as shown in the diagram below:-
- iii. Ensure that the cores marked V+ & V- do not continue into Detector No. 10. It must stop at Detector No. 9. Detectors No. 10 onwards are powered by the PB-24 Booster Box.
- iv. Cores marked Hi & Lo should daisy chain through all Detectors installed on the system.

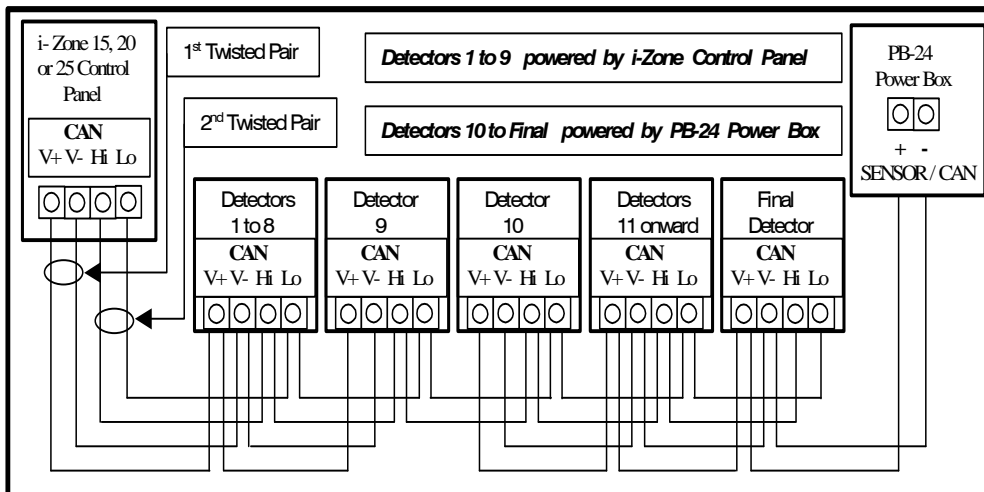

### 4. Relay Pack - SWRi-8.

**The SWRi-8 Relay Pack is capable of carrying out 2 separate functions.**

- i. It is capable of giving up to 8 Detectors a dedicated output for remote signalling via a set of 'Clean Contacts' **or**
- ii. it can be used for receiving up to 8 Volt Free Inputs from the customers own equipment . In an 'Alarm State' a signal will be sent to the i-Zone Panel and the information will be displayed on the LCD screen as follows:-

## Section G ..... (cont)

### 4. Relay Pack - SWRi-8 ..... (cont)

# PLEASE NOTE - You cannot mix items i. & ii above, it 's either or.



**SWRi-8 Dedicated Relay Pack. (Circuit Board Layout)**

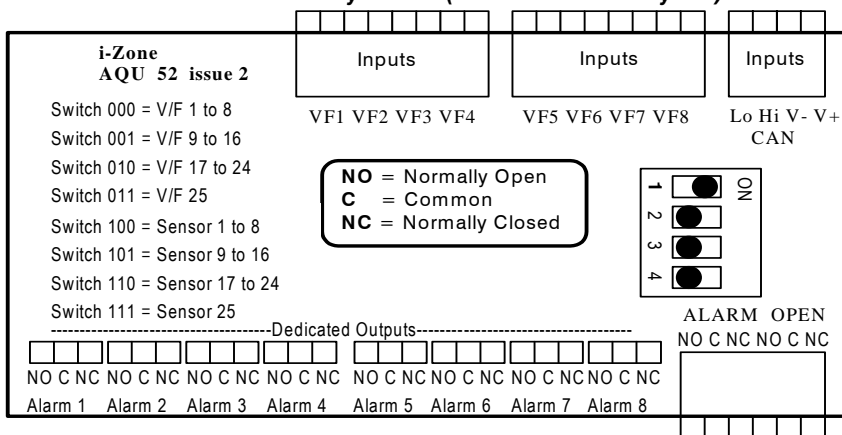

iii. **Maximum rating for Dedicated outputs = 16 Amp @ 240 volt AC.**

iv. **VF Inputs are Volt Free only.**

v. A SWRi-8 relay pack is connected to the Control Panel in the same manner as a Detector (via the 'CAN' connector) and can be installed anywhere along the string of Detectors, (capable of giving outputs for up to 8 detectors per pack) as shown below:-

**SWRi-8 Dedicated Relay Pack. (Where to position in system)**

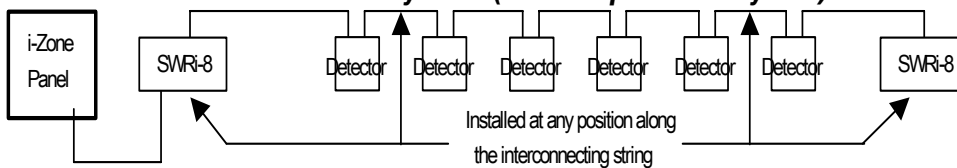

## Section G ..... (cont)

### 4. Relay Pack - SWRi-8. .... (cont)

- vi. Using the Dip Switch to set which Detectors (Zone) will turn the Relay 'ON' or if it is to be used for Customers Volt Free inputs.  
**Only dip-switch 1 to 3 are used, number 4 is non-operative.**

*Use these switch positions for Volt Free inputs from customers equipment.*

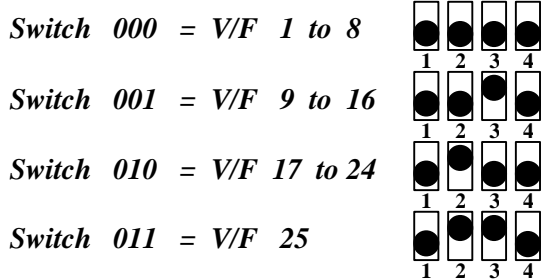

*Use these switch positions for Dedicated Detector outputs.*

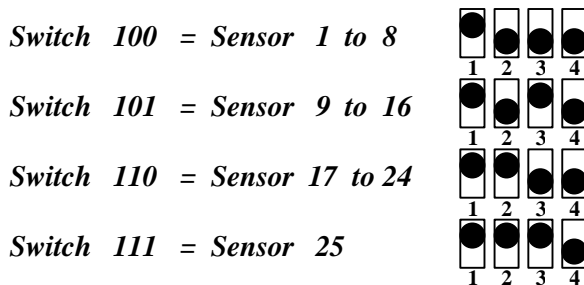

- vii. There are also a Common set of 'Clean Contacts' for both 'Alarm' & 'Open Circuit'.
- viii. Each SWRi-8 Relay Pack can be used for up to 8 Dedicated Detectors or up to 8 Volt Free Inputs from the customers own equipment only. Multiples of the Relay Pack must be used for each 8 Detectors or Inputs.

**# PLEASE NOTE - You cannot mix Dedicated Detectors & Volt Free Inputs on A SINGLE SYSTEM.**

**Section G ..... (cont)**

**5. Relay Pack - SWRi-5**

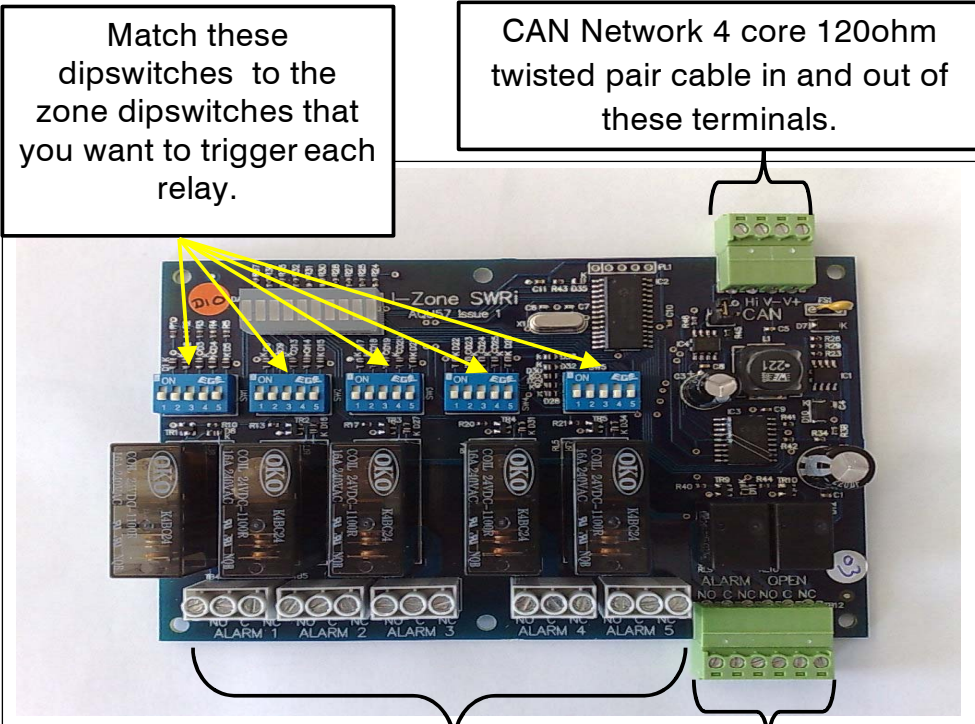

Match these dipswitches to the zone dipswitches that you want to trigger each relay.

CAN Network 4 core 120ohm twisted pair cable in and out of these terminals.

Use these terminals to pick up the Zone Dedicated Relay Outputs.  
NO = Normally Open  
C = Common  
NC = Normally Closed

These are another set of COMMON Alarm outputs, duplicating those on the main control panel

**‘Aqualarm’ SWRi-5 Relay Pack Board Layout and Terminal Identifications.**

## Section G ..... (cont)

### 5. Relay Pack - SWRi-5 ..... (cont)

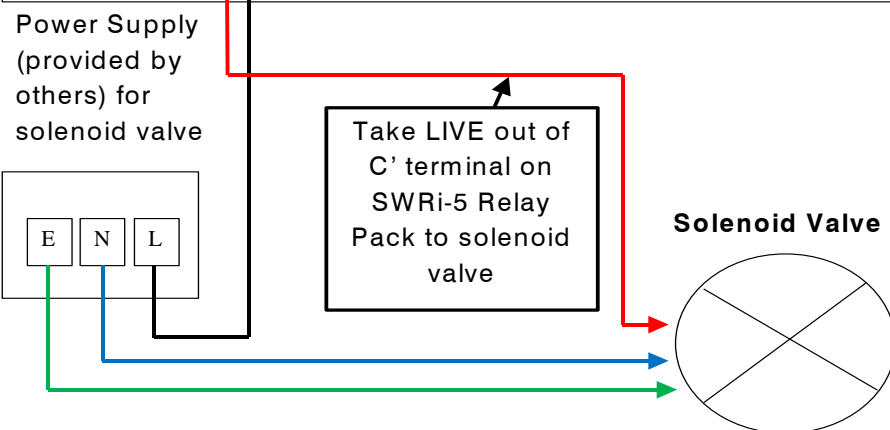
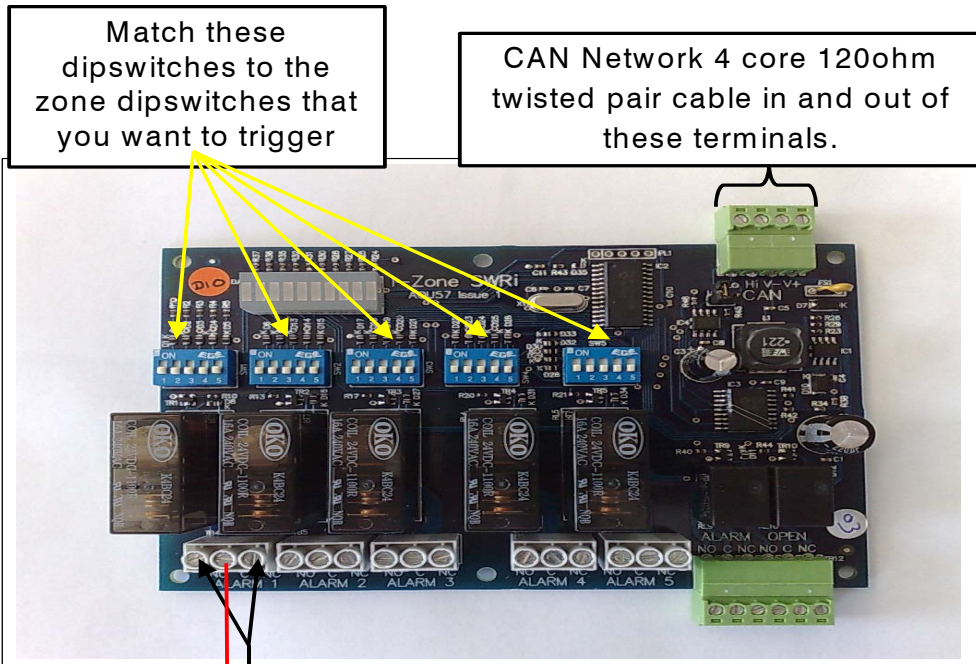

Terminate LIVE power supply into the 'NO' on the SWRi-5 Relay Pack if power is required to CLOSE Solenoid Valves.

Terminate LIVE power supply into the 'NC' on the SWRi-5 Relay Pack if power is required to OPEN Solenoid Valves.

**Section G ..... cont**  
**5. Spares.**

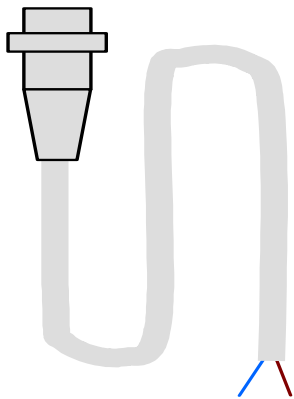

**iZ-LC Leader Cable**  
 (Can be cut to Length)

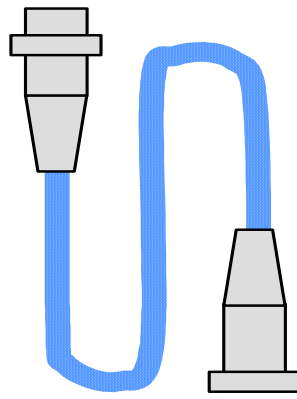

**CD-x Detecting Cable**  
 1m, 2m, 5m & 10m

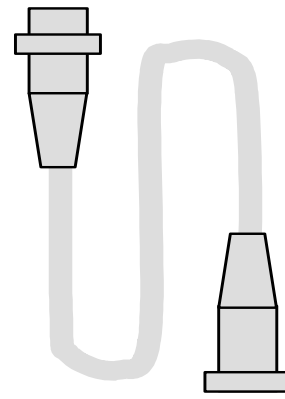

**iZ-JC Jumper Cable**  
 (Please Specify Length)

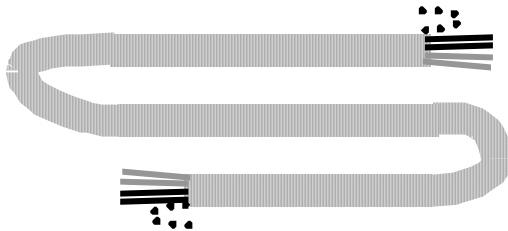

**iZ-NC Network Cable**  
 ( 4 core screened 120 ohm twisted pairs)  
 (As Beldon B9842)



**Floor Clip**  
 CL-1/10 Pack of 10  
 CL-1/100 Pack of 100

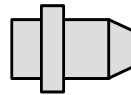

**iZ/EOL**  
 End of Line  
 Resistor

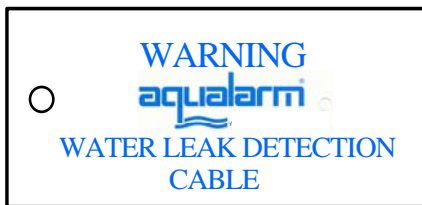

**WL-1/10 Pack of 10**  
**WL-1/100 Pack of 100**  
 Warning Labels

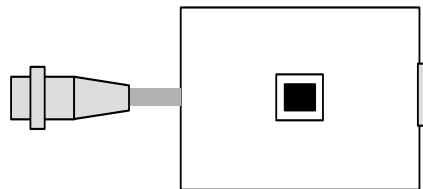

**LS-MBi Mapping Box**  
 (for use with LeakSense  
 and ZLM Module)

**Section G ..... cont**

**6. Control Panel Facia.**

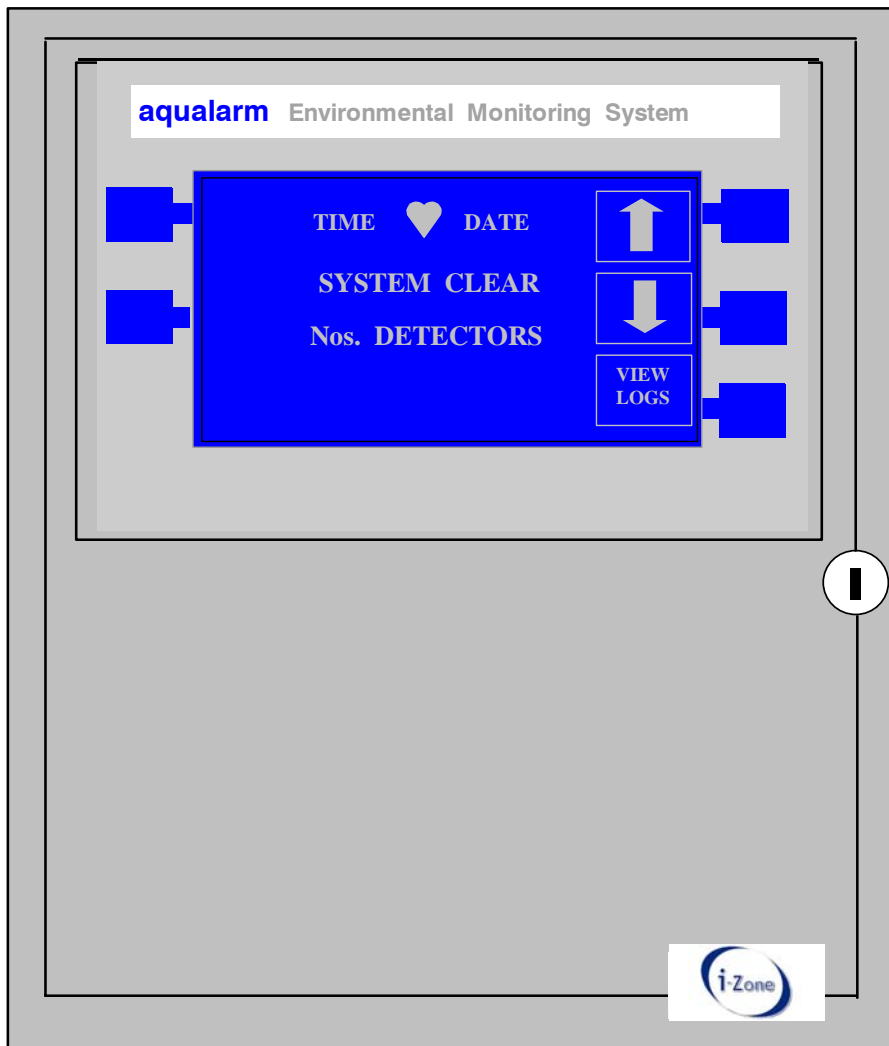

*i-Zone 5 has a Green LCD Screen with Black writing.  
i-Zone 10, 15, 20 & 25 have a Blue LCD Screen with White writing.*



QMS International plc

## Registration Certificate

This document certifies that the quality management systems of

**J.A.M. LIMITED**

have been assessed and approved by QMS International plc to the following quality management systems, standards and guidelines:-

BS EN ISO 9001 : 2008

The approved quality management systems apply to the following:-

**THE DESIGN, MANUFACTURE, SUPPLY, INSTALLATION AND MAINTENANCE OF ELECTRONIC ENVIRONMENTAL MONITORING SYSTEMS.**

Original Approval: 29 May 1997

Current Certificate: 22 February 2011

Certificate Expiry: 28 May 2017

Certificate Number: GB 1991

On behalf of QMS International plc



This Certificate remains valid while the holder maintains their quality management systems in accordance with the standards and guidelines above, which will be audited by QMS International plc  
*This Certificate is the property of QMS International plc and must be returned in the event of cancellation.*

QMS  
International plc



**QMS Quality Management Systems**

## Registration Certificate

This document certifies that the environmental management systems of  
**J.A.M. LIMITED**

have been assessed and approved by QMS Quality Management Systems to the following environmental management systems, standards and guidelines:-  
BS EN ISO 14001 : 2004

The approved environmental management systems apply to the following:-  
**THE DESIGN, MANUFACTURE, SUPPLY, INSTALLATION AND MAINTENANCE  
OF ELECTRONIC ENVIRONMENTAL MONITORING SYSTEMS.**

Original Approval: 20 February 2003

Current Certificate: 27 July 2005

Certificate Expiry: 19 February 2013

Certificate Number: GB 10787

  
On behalf of QMS International plc



This Certificate remains valid while the holder maintains environmental management systems in accordance with the standards and guidelines above, which will be audited by QMS Quality Management Systems  
*This certificate is the property of QMS International plc and must be returned in the event of cancellation.*

A division of **QMS**  
International plc

**WASTE ELECTRICAL AND ELECTRONIC  
EQUIPMENT REGULATIONS 2006**

THIS IS TO CERTIFY THAT

**J.A.M. LTD**

---

IS A MEMBER OF THE PRODUCER COMPLIANCE SCHEME

**ECONO-WEEE LTD**

FOR THE 2008 COMPLIANCE PERIOD

REGISTRATION NUMBER:

**WEE/CC0590TQ**

---



John Kerr

(Directors)



David Adams

# MAPPING RESULTS SHEET

**Project Name** .....**Date**.....

<i>Position Log No.</i>	<i>Cable Length &amp; Type</i>	<i>Alarm Reading</i>	<i>Open Circuit Reading</i>

<i>Position Log No.</i>	<i>Cable Length &amp; Type</i>	<i>Alarm Reading</i>	<i>Open Circuit Reading</i>

***When all Readings have been recorded, the information should be used to prepare a 'System Map'***

# MAPPING RESULTS SHEET

Project Name .....Date.....

<i>Position Log No.</i>	<i>Cable Length &amp; Type</i>	<i>Alarm Reading</i>	<i>Open Circuit Reading</i>

<i>Position Log No.</i>	<i>Cable Length &amp; Type</i>	<i>Alarm Reading</i>	<i>Open Circuit Reading</i>

**Important Information for correct disposal of  
this product in accordance with  
EC Directive 2002/96/EC**

i. *At the end of its working  
life, the product must not be  
disposed of as urban waste.*

ii. *It must be taken to a  
special local authority,  
differentiated waste collection  
centre or returned to  
J.A.M. Limited.*

iii. *Disposing of products separately avoids  
possible negative consequences for the  
environment and health deriving from inappropriate  
disposal and enables the constituent materials to  
be recovered to obtain significant savings in energy  
and resources and create a better future for Earth  
and our descendants..*

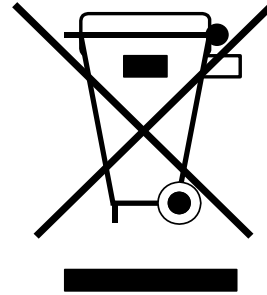

**CE Marking.**

i. *Equipment manufactured in accordance  
with EEC Directives:-  
98/13/EEC & 2006/95/EC*

## **NOTES**

### **DUTY OF CARE**

*It is our recommendation that all equipment installed is made accessible for maintenance, repair or replacement. J.A.M. Limited will not accept any responsibility or costs involved should the necessary access not be made.*

**AUTHORISED AGENT**

**J.A.M. Limited**

**39 Brook Road, Rayleigh  
Essex, SS6 7XJ, England**

**TEL: +44 (0) 1268 777222  
FAX: +44 (0) 1268 777221**

**Web Site : [www.jam.uk.com](http://www.jam.uk.com) – E-Mail : [jam.ltd@virgin.net](mailto:jam.ltd@virgin.net)**

'aqualarm', 'LeakSense', 'aqualarm OneTouch' & 'i-Zone' are  
registered Trade Marks of J.A.M. Limited, England

MAY 2011